

Pneumatically operated 2/2 way valve with PTFE bellow

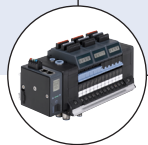

- High Medium resistance
- Easy to clean for hygienic applications
- Long service life
- Compact

Type 2080 can be combined with...



Type 8652
AirLINE Valve island



Type 8036
Flow sensor



Type 2380
Bellow Control Valve

The valve consists of a pneumatically piston actuator with return spring, a stainless steel body and PTFE bellows. The PTFE bellows are used for the separation of the medium. With the appropriate installation (body to bottom) the valve is self-draining. The materials used and the internal contours are simple to clean (CIP and SIP). The valve is suitable for food technology. The modular structure permits configuration with different armatures and customized port connectors. The pneumatic actuator is servo assisted by a pilot valve, a valve block or similar.

Technical data	
Orifice	DN10, DN6 (flange), others on request
Actuator size	piston diam. 28 mm
Medium	Neutral to aggressive gases and liquids
Medium pressure range	Vacuum up to 8 bar
Medium temperature	see PT-Diagram
Port connections	Threaded port G 3/8, weld end, flange connection
Pilot air connections	Threaded port G 1/8
Position detection	Reedcontact (two wire, closer), cable length: 3 m
Installation	Upright assembly for self-draining (body to bottom)
Body material	Stainless steel 316Ti (1.4571), with flange 316L (1.4404)
Actuator material	Stainless steel 304L (1.4301)
Bellows material	Advanced PTFE
Wetted materials	Stainless steel 316Ti /316L, advanced PTFE
Back pressure	Tight to 8 bar
Ground leakage	5 Nml/min, measured with air 8 bar below seat
Pilot air pressure	4.5 to 10 bar
Pilot fluid	Neutral gases, air
Ambient temperature	Max. +90 °C
Surface finish	Surface finish Ra=0.8, others on request
Special features	- With self-draining operation - Suitable for CIP and SIP (cleaning in process) - Suitable for foodstuffs - FDA conform
Flow rate	Measured at +20 °C, 1 bar pressure at valve inlet and free outlet
K_v value water [m³/h]	
Pressure values [bar]	Overpressure with respect to atmospheric pressure
Flow direction (liquids)	below seat (pressure on port connection 2)

Material

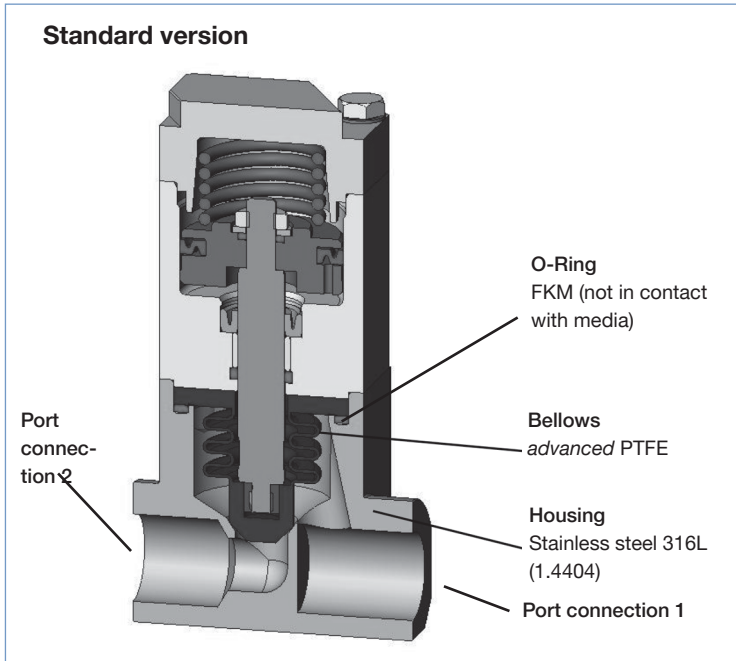

Pressure temperature characteristics

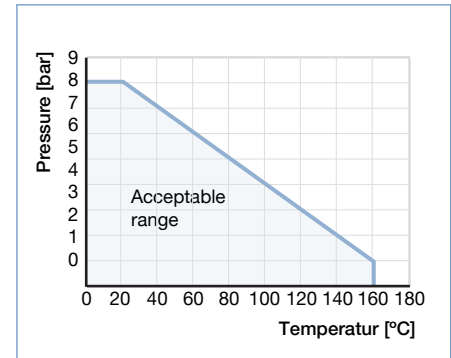

Ordering chart for valves (other versions on request)

All valves with pilot air ports G 1/8 and actuator body in stainless steel

Circuit function	Actuator version	Orifice [mm]	K _v value [m³/h]	Medium connection	Article no.
<p>A</p> <p>Pneumatically operated on / off valve, normally closed by spring force, flow direction above seat</p>	On-Off	10	1.14	Threaded port G 3/8	180729
		10	1.14	Weld end acc. to BS 4825 (12.7 × 1.2)	179582
		10	1.14	Weld end acc. to ISO 4200 (13.5 × 1.6)	186407
		10	1.14	Weld end acc. to DIN 11850-2 (13 × 1.5)	186409
		6	0.64	Flange port	182863
		-		without body (only actuator)	180555

on request:

- normally open version (control function B, CF B)
- mechanical stroke limiter for safer flow adjustment (VAR CODE MJ33)
- 3-position actuator (control function A, paths/positions 6)

