



## Flowmeter for gases

- Thermal mass flow measurement
- Integrated inlet and outlet pipes for flow conditioning
- Pipe sizes up to 2"
- Integrated display
- Standard and Heavy Duty version available

Product variants described in the data sheet may differ from the product presentation and description.

### Can be combined with

	<b>Type 3280</b> 2-way motor valve	▶
	<b>Type 3285</b> 2/2 way Proportional Valve (motor-driven)	▶
	<b>Type 8611</b> eCONTROL - Universal controller	▶
	<b>Type 8802</b> ELEMENT continuous control valve systems - overview	▶

### Type description

This flowmeter series is made for measuring of especially large flow rates and uses the calorimetric measuring principle. A heated sensor element is cooled down by the gas flow. This cooling effect which depends on the flow velocity and the gas characteristics is the measure for the mass flow rate. This kind of mass flow measurement is independent of pressure and temperature. The flowmeter can be used for monitoring air supplies, but also qualifies for measuring other gases - given the corresponding calibration.

The display can be rotated by 180°. Further there is a totaliser integrated which counts the gas volume flowing through the pipe. It can be reset by the console. The flowmeter's pressure drop is negligibly low, the measurement works without any moving parts.

In combination with a solenoid control valve or an air operated process control valve decentralized flow control loops up to DN50 are possible.

Type 8008 is available in two versions: - Standard - Heavy Duty (with a robust aluminium die casting electronics housing).

In the Heavy Duty version the sensor is encapsulated in stainless steel.

## Table of contents

<b>1. General technical data</b>	<b>3</b>
<b>2. Dimensions</b>	<b>4</b>
2.1. Standard version threaded .....	4
2.2. Standard version flange .....	4
2.3. Heavy Duty version threaded .....	5
2.4. Heavy Duty version flange .....	5
<b>3. Device / Process connections</b>	<b>6</b>
3.1. Connection details standard version .....	6
Pin Assignment .....	6
3.2. Connection details Heavy Duty version .....	7
<b>4. Product installation</b>	<b>8</b>
4.1. Installation notes .....	8
<b>5. Product operation</b>	<b>8</b>
5.1. Flow Ranges .....	8
<b>6. Ordering information</b>	<b>9</b>
6.1. Ordering chart standard version .....	9
6.2. Ordering chart Heavy Duty version .....	9
6.3. Ordering chart accessories standard version .....	10

## 1. General technical data

Product properties	
Dimensions	Detailed information can be found in chapter <b>"2. Dimensions"</b> on page 4.
Materials	
Body	Stainless steel 1.4301 (Standard), Stainless steel 1.4571 (Heavy Duty)
Electronics housing	Polycarbonate (Standard), Aluminium die casting (Heavy Duty)
Sealing	NBR, FKM (for oxygen)
Full scale ranges ( $Q_{Nom}$ ) <sup>1.)</sup>	Up to 1100 Nm <sup>3</sup> /h (air) Detailed information can be found in chapter <b>"5.1. Flow Ranges"</b> on page 8.
Electrical data	
Output signal	Actual valve output: 4...20 mA Max. load (current output): <500 Ω
Pulse output	1 pulse per m <sup>3</sup>
Digital output	RS 485 interface, Modbus-RTU
Power supply	18...36 V DC, 5 W
Performance data	
Operating pressure (max.)	Up to max. 16 bar; optional up to PN40 (Standard) Up to max. 50 bar (Heavy Duty)
Accuracy	± 1.5 % v. M. <sup>2.)</sup> ± 0.3 % v. E. <sup>3.)</sup> (related to air and in consideration of the specified inlet and outlet distances); absolute accuracy is guaranteed during conversion from – exhaled – operating media impaired
Span	1:50
Medium data	
Operating medium	Air, nitrogen, oxygen, natural gas, methane, argon, carbon dioxide, biogas (on request), LPG (on request)
Calibration medium	Air
Gas temperature	-30 °C...+80 °C (higher temperatures on request)
Approvals and certificates	
Protection class	IP65
Approval & Conformity	O <sub>2</sub> -certificate (optional) Oil and grease free cleaned (optional)
Product connections	
Pipe connection	R1½", R¾", R1", R1¼", R1½", R2" (all connections as external thread) acc. to DIN EN 10226 (ISO 7–1) or or flange connections acc. to DIN EN 1092–1 (Stainless steel 1.4404), other connections on request
Electrical connection	Detailed information can be found in chapter <b>"3. Device / Process connections"</b> on page 6.
Environment and installation	
Ambient temperature (max.)	-30 °C...+80 °C (higher temperatures on request)

1.) For 1.013 bar(ü) and 0 °C (acc. to DIN 1343)

2.) o.R.: of reading

3.) F.S.: full scale (full scale values see **"5.1. Flow Ranges"** on page 8)

## 2. Dimensions

### 2.1. Standard version threaded

**Note:**

Dimensions in mm

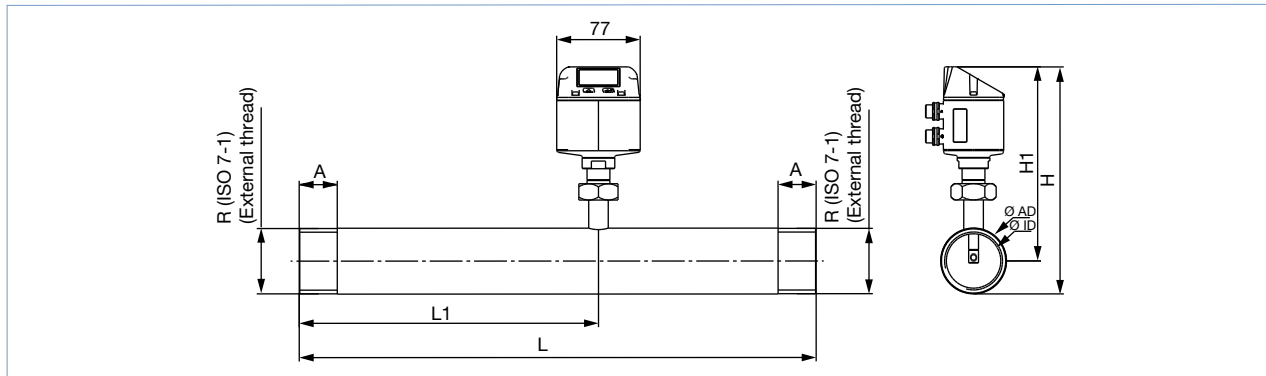

Measuring distance		Ø AD Pipe	Ø ID Pipe	L	L1	H	H1	A
[Inch]	[DN]	[mm]	[mm]	[mm]	[mm]	[mm]	[mm]	[mm]
½	15	21.3	16.1	300	210	176.4	165.7	20
¾	20	26.9	21.7	475	275	179.2	165.7	20
1	25	33.7	27.3	475	275	182.6	165.7	25
1¼	32	42.4	36	475	275	186.9	165.7	25
1½	40	48.3	41.9	475	275	186.9	165.7	25
2	50	60.3	53.1	475	275	186.9	165.7	30

### 2.2. Standard version flange

**Note:**

Dimensions in mm

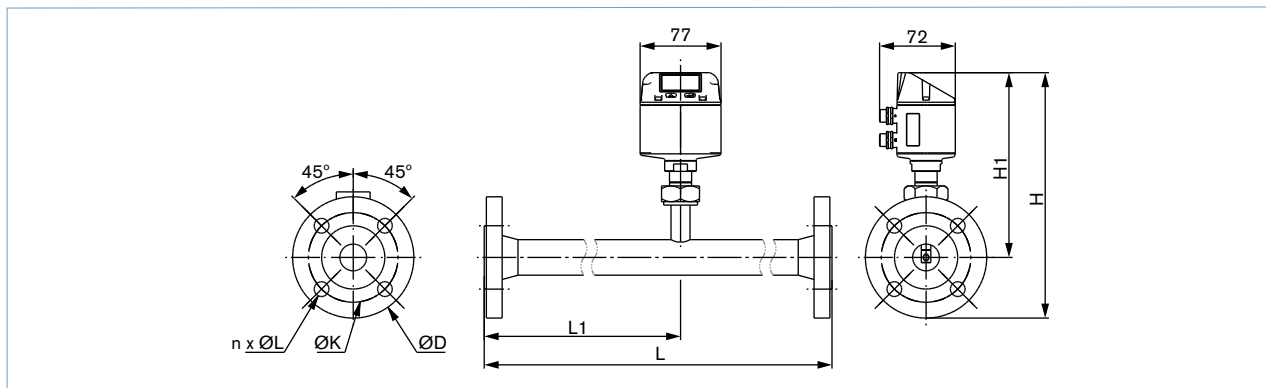

Measuring distance		Ø AD Pipe	Ø ID Pipe	L	L1	H	H1	Ø D	Ø K	n x Ø L
[Inch]	[DN]	[mm]	[mm]	[mm]	[mm]	[mm]	[mm]	[mm]	[mm]	[mm]
½	15	21.3	16.1	300	210	213.2	165.7	95	65	4 x 14
¾	20	26.9	21.7	475	275	218.2	165.7	105	75	4 x 14
1	25	33.7	27.3	475	275	223.2	165.7	115	85	4 x 14
1¼	32	42.4	36	475	275	235.7	165.7	140	100	4 x 18
1½	40	48.3	41.9	475	275	240.7	165.7	150	110	4 x 18
2	50	60.3	53.1	475	275	248.2	165.7	165	125	4 x 18
2½	65	76.1	68.9	475	275	268.2	175.7	185	145	8 x 18
3	80	88.9	81.9	475	275	275.7	175.7	200	160	8 x 18

DTS 1000196002 EN Version: N Status: RL (released | freigegeben | valide) printed: 18.06.2019

### 2.3. Heavy Duty version threaded

**Note:**  
Dimensions in mm

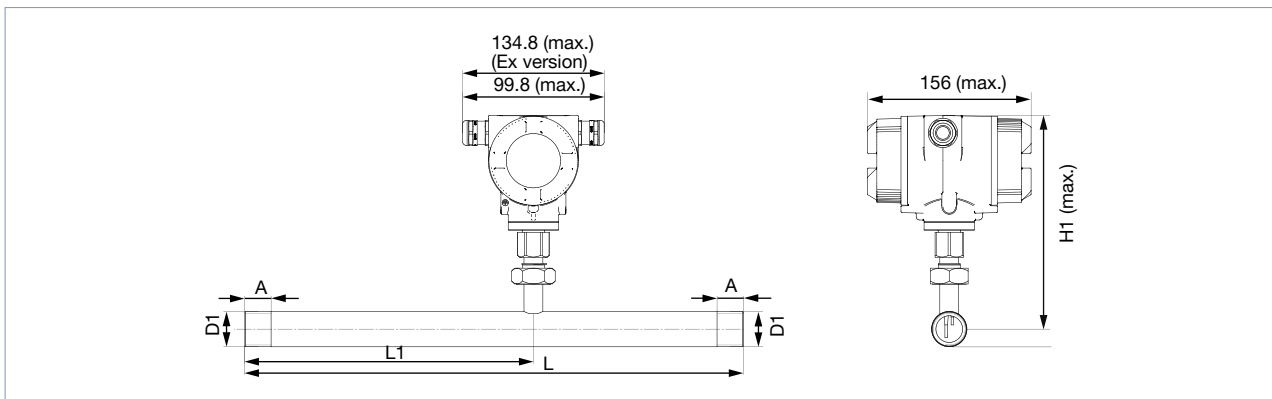

Connection thread [Inch]	Ø AD Pipe [mm]	Ø ID Pipe [mm]	L [mm]	L1 [mm]	H [mm]	H1 [mm]	A [mm]
R 1/2	21.3	16.1	300	210	176.4	165.7	20
R 3/4	26.9	21.7	475	275	179.2	165.7	20
R 1	33.7	27.3	475	275	182.6	165.7	25
R 1 1/4	42.4	36	475	275	186.9	165.7	25
R 1 1/2	48.3	41.9	475	275	186.9	165.7	25
R 2	60.3	53.1	475	275	186.9	165.7	30

### 2.4. Heavy Duty version flange

**Note:**  
Dimensions in mm

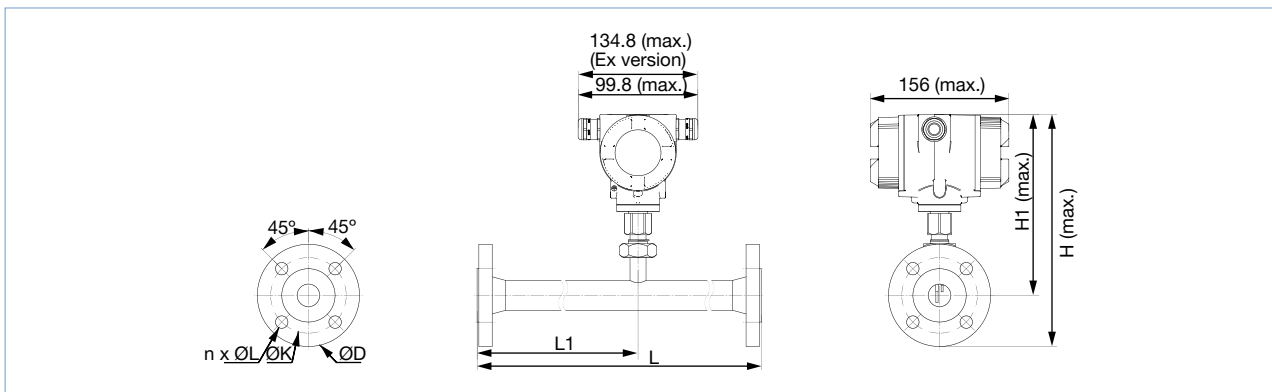

Measuring distance [DN]	Ø AD Pipe [mm]	Ø ID Pipe [mm]	L [mm]	L1 [mm]	H [mm]	H1 [mm]	Flange DIN EN 1092-1		
							[Ø D mm]	[Ø K mm]	[n x Ø L mm]
15	21.3	16.1	300	210	213.2	165.7	95	65	4 x 14
20	26.9	21.7	475	275	218.2	165.7	105	75	4 x 14
25	33.7	27.3	475	275	223.2	165.7	115	85	4 x 14
32	42.4	36	475	275	235.7	165.7	140	100	4 x 18
40	48.3	41.9	475	275	240.7	165.7	150	110	4 x 18
50	60.3	53.1	475	275	248.2	165.7	165	125	4 x 18

DTS 1000196002 EN Version: N Status: RL (released | freigegeben | valide) printed: 18.06.2019

### 3. Device / Process connections

#### 3.1. Connection details standard version

##### Pin Assignment

##### Note:

- The Pin assignment was changed with the new device generation. For questions, please contact the responsible Bürkert facility.
- If the sensor is placed at the end of the Modbus system a termination is required. The sensors have an internal switchable termination. To use that the 6 fastening screws from the lid must be released and the internal DIP Switch must be set to “On”. Please ensure that the connection plugs are still plugged and the gasket is installed correctly. Alternatively, a 120R resistor can be installed in the plug between pin 2 and pin 4.

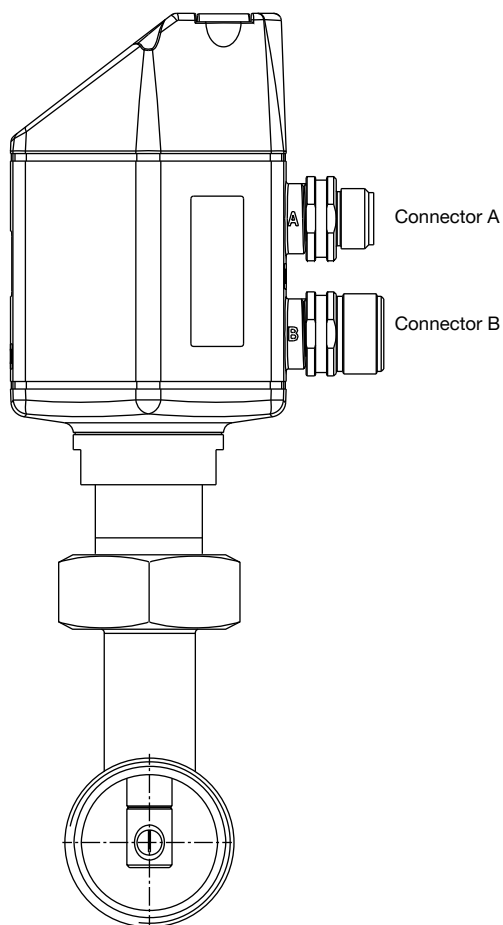

M12 connector

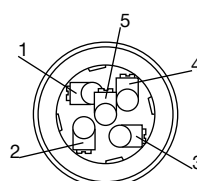

M12 connector A

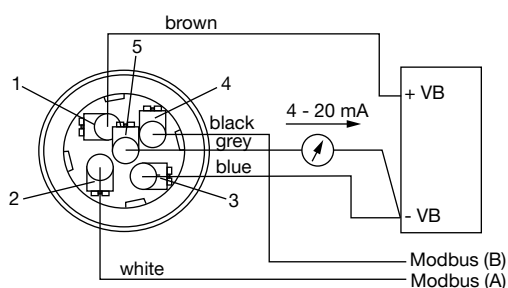

M12 connector B

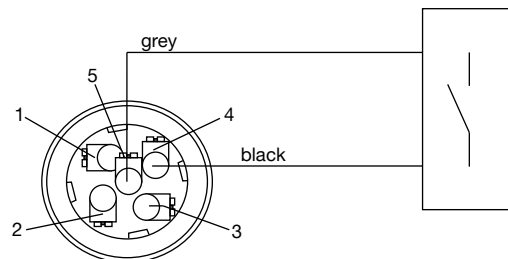

Pin	Connector A (Anschlussleitung)	Connection cable A	Connector B (pulse port)	Connection cable B
1	VB + Positive voltage supply 12...36 V DC smoothed	Brown	Not assigned, just for internal use only <sup>1.)</sup>	Brown
2	RS 485 (A) Modbus-RTU A	White	GND	White
3	VB - Negative voltage supply 12...36 V DC smoothed	Blue	DIR Direction input	Blue
4	RS 485 (B) Modbus-RTU b	Black	P Pulse for usage	Black
5	I + Current signal 4...20 mA - selected measurement signal	Grey	P Pulse for usage	Grey

1.) Do not connect Pin 1 (Connector B) with an electrical potential and/or ground.

### 3.2. Connection details Heavy Duty version

**Note:**

Electrical connection Modbus:  
 If the sensor is used at the end of the Modbus system a bus termination is required. Please connect the enclosed 120R resistor to the terminals, Pin 1 and 3 of "X2" connector.

Plug layout

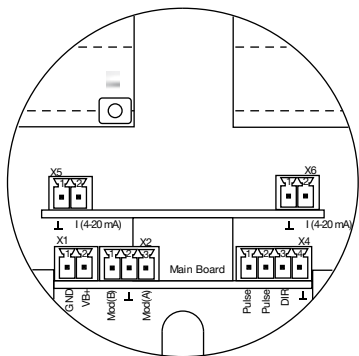

Voltage supply

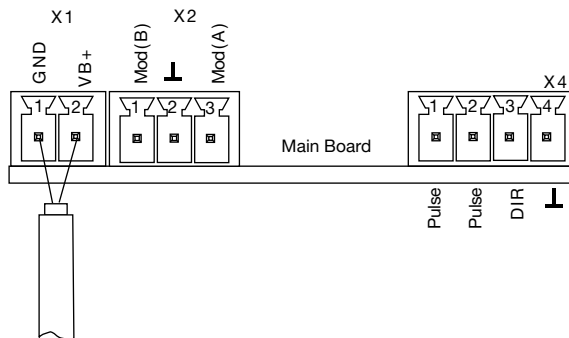

Modbus

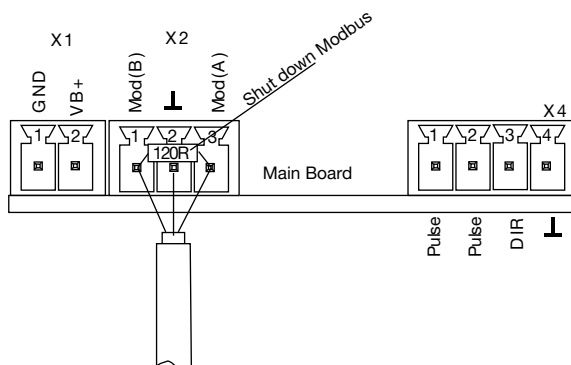

Plug	Pin	Description
X1 Voltage supply	1	VB - (negative voltage supply GND)
	2	VB + (positive voltage supply 12 V...36 V DC)
X2 Modbus	1	Modbus (B)
	2	Modbus shield
	3	Modbus (A)
X4 Direction/impulse	1	Pulse/Alarm <sup>1.)</sup>
	2	Pulse/Alarm <sup>1.)</sup>
	3	Direction input
	4	GND
X5 Power output 1	1	I- Active <sup>1.)</sup>
	2	I+ Active <sup>1.)</sup>
X6 Power output 2	1	I- Active <sup>1.)</sup>
	2	I+ Active <sup>1.)</sup>

1.) All analog outputs are galvanically isolated.

## 4. Product installation

### 4.1. Installation notes

**Note:**

- DN corresponds to pipe diameter
- The flow direction in the following illustrations is always from left to right.

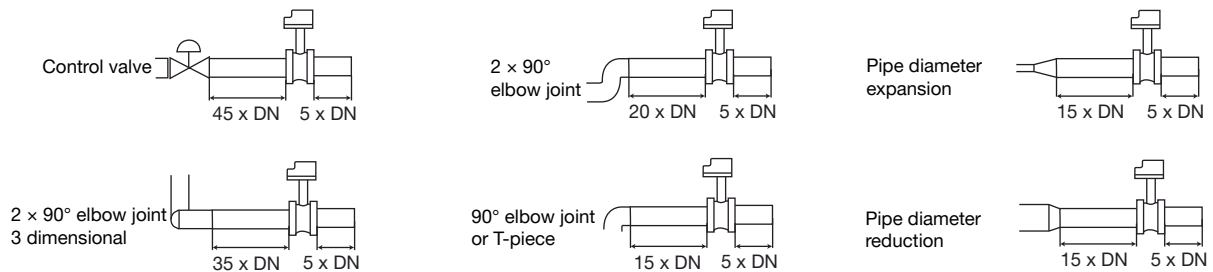

## 5. Product operation

### 5.1. Flow Ranges

**Note:**

- The table below lists the final flow rate value for flow velocities up to 185 m/s. Lower/higher final flow values relative to pipe diameter can be achieved by adjusting the maximum flow velocity during calibration. The optimal design of the devices is done automatically when the order is placed.
- Article no. for a flow meter calibrated on other gases like air and other flow ranges are on request. Detailed information can be found in forms at the end of this document.

Operating medium	Formula	½"	¾"	1"	1¼"	1½"	2"
		[m³/h]	[m³/h]	[m³/h]	[m³/h]	[m³/h]	[m³/h]
<b>Ref. acc. to DIN 1945/ISO 1217: 20 °C and 1000 mbar</b>							
Air	–	90	170	290	530	730	1195
<b>Ref. acc. to DIN 1343: 0 °C and 1013.25 mbar</b>							
Air	–	80	160	270	490	670	1100
Argon	Ar	140	275	460	830	1140	1870
Carbon dioxide	CO <sub>2</sub>	90	175	290	525	720	1185
Nitrogen	N <sub>2</sub>	80	160	270	485	670	1100
Oxygen	O <sub>2</sub>	85	165	280	505	695	1140
Natural gas, methane	NG	50	105	170	310	430	705









## 6. Ordering information

### 6.1. Ordering chart standard version

**Note:**

- Air with operating pressure of 6 bar(ü)
- The total length of the device is not enough to condition the flow. Please refer to the design notes.
- Calibration for another flow range, other gases and/or operating pressure are available on request.







Pipe connection [Inch]	Inner diameter of pipe [mm]	Flow range [Nm <sup>3</sup> /h] <sup>1.)</sup>	Overall length [mm]	Article no.
R ½	16.1	Up to 80	300	773501 
R ¾	21.7	Up to 160	475	773502 
R 1	27.3	Up to 270	475	773503 
R 1¼	36.0	Up to 485	475	773504 
R 1½	41.8	Up to 670	475	773505 
R 2	53.1	Up to 1100	475	773506 

1.) Index N: Standard condition, flow rate referred to 0 °C and 1.013 bar(a)

### 6.2. Ordering chart Heavy Duty version

**Note:**

- Air with operating pressure of 6 bar(ü)
- Calibration for another flow range, other gases and/or operating pressure are available on request.







Pipe connection [Inch]	Inner diameter of pipe [mm]	Flow range [Nm <sup>3</sup> /h] <sup>1.)</sup>	Overall length [mm]	Article no.
R ½	16.1	Up to 80	300	773511 
R ¾	21.7	Up to 160	475	773512 
R 1	27.3	Up to 270	475	773513 
R 1¼	36.0	Up to 485	475	773514 
R 1½	41.8	Up to 670	475	773515 
R 2	53.1	Up to 1100	475	773516 

1.) Index N: Standard condition, flow rate referred to 0 °C and 1.013 bar(a)

### 6.3. Ordering chart accessories standard version

**Note:**

If no connection cable/impulse cable is ordered, the device is supplied with an M12 connector plug (connection A).

Description	Article no.
5 m cable, with 5 pin M12 plug at one end	770217 
10 m cable, with 5 pin M12 plug at one end	770795 
Power supply Type 1573 for rail mounting, 100...240 V AC/ 24 V DC, 1.25A, NEC Class 2 (UL 1310)	772438 
Power supply Type 1573 for rail mounting, 100...240 V AC/ 24 V DC, 1A, NEC Class 2 (UL 1310)	772361 
Power supply Type 1573 for rail mounting, 100...240 V AC/ 24 V DC, 2A, NEC Class 2 (UL 1310)	772362 
Power supply Type 1573 for rail mounting, 100...240 V AC/24 DC, 3.8A NEC Class 2 (UL60950 - 1)	772898 
Service Software	773890 

# Bürkert – Close to You

For up-to-date addresses  
please visit us at  
[www.burkert.com](http://www.burkert.com)

DTS 1000196002 EN Version: N Status: RL (released | freigegeben | validé) printed: 18.06.2019



# Request for Quotation

## Note

You can fill out the fields directly in the PDF file before printing out the form.

Please complete and send to your nearest Bürkert sales centre

Company	Contact person
Customer no.	Department
Address	Phone/Fax
Postcode/Town	E-mail

Quantity  required delivery date

Version  Standard  Heavy Duty

## Operating Data

Gas:  Air  Argon  Nitrogen  Methane  
 Oxygen  Carbon dioxide  Natural gas  
 Other gas:

Max. flow rate:   m<sup>3</sup>/h  
 l/min

Reference conditions:  N: 0 °C, 1013 mbar(a)  
 S: 20 °C, 1000 mbar(a)

Other unit

Operating pressure  bar(ü)

Ambient temperature:  °C  °F

Medium temperature:  °C  °F

Pipe connection:  ½" external  ¾" external  1" external  Flange:   
 1¼" external  1½" external  2" external  Other:

Options:  Free of oil and fat, without O<sub>2</sub> certificate  
 Free of oil and fat, with O<sub>2</sub> certificate  
 High pressure up to 40 bar

## Comments / Sketch